

1. Product Description

Spal-Pro RSF is a rapid-setting, two-component polyurea liquid of 100% solids content. When cured, Spal-Pro RSF is a medium gray solid with a hard rubber-like hardness of A88-94 depending upon temperature. Spal-Pro RSF is designed for use in areas where final temperatures range from +120°F (49°C) to -30°F (-34°C).

Spal-Pro RSF's primary use is as a filler for control and construction joints in floor areas subjected to hard wheel vehicles. It is also ideal for filling joints in non-traffic areas such as under racks, at walls, at column diamonds and for filling random cracks.

Due to Spal-Pro RSF's rapid gel time of 2-3 minutes, it must be installed using a dual-feed power dispensing system or with pre-filled dual cartridges available from manufacturer. Manual dispensing is impractical.

Limitations

- Spal-Pro RSF has limited expansion capabilities due to its relatively high hardness.
- Spal-Pro RSF is intended for interior use only. Exposure to sunlight or other sources of UV rays can cause discoloration.
- Contact manufacturer if product will be exposed to direct chemical contact once installed.

2. Material Storage

Keep Spal-Pro RSF in tightly sealed containers in dry, shaded areas where temperatures average 70°F to 85°F (21°C to 30°C). Protect from sunlight, freeze-thaw and excessive temperatures.

3. Timing of Installation

Installation should be deferred until refrigerated areas have been down to their ultimate operating temperature. ACI recommends that temperature be held stable for seven days or longer before filling.

4. Equipment and Tools

Spal-Pro RSF must be installed using dual-feed, power dispense pump systems set at 1:1 by volume mix ratio, or with pre-filled, dual cartridge units supplied by the manufacturer. Pump equipment must be retrofitted with a heating system to keep reservoir tanks, lines and mixer head warm. Cartridge units must be heated before use. Additional equipment needed includes all safety gear, ratio verification system, wiper rags, solvent, etc.

5. Joint Design Details

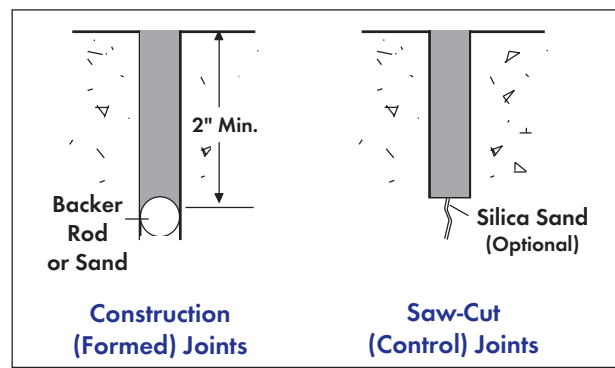

NOTE ON REPAIRS:

For floor repairs (gouges, delamination, wide joint spalling, etc.) we recommend using our Spal-Pro 2000.

6. Joint Preparation

Joints should be completely free of saw laitance, dirt, debris, coatings/sealers and frost or visible moisture. Joint cleaning procedures must accomplish the removal of all of the above. Failure to do so will compromise adhesion. Simply "raking" debris out of joint is not an acceptable cleaning method. Preferred methods of joint cleaning include using a dustless concrete saw with diamond blade (ensure blade is slightly wider than joint or clean both sides). No primer is needed. If unusual conditions are present, contact Metzger/McGuire.

Choking off the base of the joint is normally not required due to Spal-Pro RSF's rapid set, but applicator may choke-off the shrinkage crack if it is excessively wide (as shown in joint design, section 5). **Do not use compressible backer rod (Ethafom, etc) in saw cut joints.** For adhesion to steel, mechanically abrade steel to insure mechanical bond. Call M/M for additional methods.

The "Heavy Duty"
Polyurea Filler for
Class 5-9
Industrial Concrete Floors

SPAL-PRO
RSF

INSTALLATION INSTRUCTIONS

7. Installing at Various Temperatures

Spal-Pro RSF's working (gel) time and cure rates will vary slightly depending on work area temperature and temperature of product at time of installation. In general, the gel/cure times will be shorter when the area and product temperatures are higher.

8. Installation of Spal-Pro RSF

Important: Thoroughly read MSDS and balance of these instructions before opening containers or attempting to install. Wear/use all personal safety equipment called for in MSDS and follow all cautions concerning working environment.

Product Settlement, Surface Skin, Etc.

Product component A (gray part) may settle during storage and/or shipment. Thoroughly mix (drill and paddle) to redistribute all components before using. Place nitrogen blanket or other desiccant over any partially used B part material in containers.

Dual-Cartridge kits may also incur settlement. Aggressively shake to re-disperse all chemicals.

Pre-Dispensing Measures

Power Dispenser - Run parts A and B through separate lines into cup before affixing mixing head or static mixer. This reduces chances of air entrapment which could cause ratio to vary.

Cartridges - See cartridge use instruction sheet packaged with product.

Mixing Ratio: 1A:1B by Volume
Part A (Gray) to 1 Part B (Amber)

When using a power dispensing unit, the feed lines, applicator wand and reservoir tanks must be heated and insulated to keep material warm and viscous. We recommend keeping material at 75 °F to 85 °F for best results.

Dual cartridge units should be maintained at about the same temperature by keeping them in a warming box or warm/hot water.

Filling Joints and Cracks

All fillers including Spal-Pro RSF have the potential to leave residue or stain on adjacent slab surface. If appearance is important, or if coating/sealer is to be applied later, protect adjacent surfaces with tape, soap, or removable sealer. Avoid getting sealer inside joint or crack; adhesion could be compromised. Best method is to apply protective media prior to joint cleaning procedure.

Joint should be filled in one pass, filling from bottom to top to avoid entrapping air bubbles.

Spal-Pro RSF is only effective when its finished profile is flush with the floor surface. To achieve this, we recommend overfilling (crowning) then razoring off the excess after the product has converted into a complete solid. Razoring is best achieved 1- 5 hours after filling, depending on the area temperature. After five hours the filler's increasing hardness may make shaving more difficult so it is recommended that the installer continually monitor the material's cure to find the best window for shaving the material flush with the surface.

9. Caution on Chemical Cure

Spal-Pro RSF cures chemically through a reaction of parts A & B. Exercise caution during cure; do not inhale fumes, do not get chemicals on skin or in eyes. See MSDS.

10. Low Fills, Bubbles

Should Spal-Pro RSF cure too low, solvent wipe and apply additional filler. Spal-Pro RSF adheres well to itself. Abrading the first pass will provide mechanical bond insurance for second pass. If bubbling or air entrapment occur, follow material application with a propane torch or heat gun to eliminate air pockets. Heat should be applied prior to initial cure (within approx. 5 minutes).

02/08

The "Heavy Duty"
Polyurea Filler for
Class 5-9
Industrial Concrete Floors

SPAL-PRO
RSF

INSTALLATION INSTRUCTIONS

11. After the Installation

Clean-Up

Clean all tools and spills of unreacted material with solvent (toluol, xylol, MEK, etc.). Cured material can be removed by razoring or sanding.

Surface Treatments

If the floor is to be acid-etched, Blast-Trac'd or coated, allow several days cure if possible. A test coat is always advisable. Once cured, Spal-Pro RSF is not affected by mechanical cleaning or most scrubbing compounds.

Traffic Exposure

Time required prior to exposure to traffic will depend on room operating temperature and product temperature when installed. In general, Spal-Pro RSF is ready for light traffic in 2 hours and full, heavy traffic in 4 hours. Always test the filler for hardness prior to traffic exposure.

12. Joint Filler Separation

Separation (adhesive or cohesive) is possible if filler is installed earlier than ACI recommendations. Separation may also occur if area temperature drops considerably as a result of intentional draw down. Separation voids may then be refilled with additional Spal-Pro RSF. See Joint Filler Tech Series Sheet T-5 "Joint Filler Separation; Causes and Correction" for more information.

IMPORTANT: Thoroughly read MSDS before opening containers or attempting to use

13. Safety Precautions (Abbreviated)

Warning for Food-Related Facilities

All chemicals, including products made by our company and our competitors, have the potential to contaminate exposed food, packaged food, and food packaging supplies. Contamination can occur if goods are present when chemicals are used, or if goods are brought into the affected area after use but prior to the removal of any residual contamination. USDA, FDA and other laws and regulations may require the removal or careful protection of food and supplies, followed by possible odor removal and/or cleaning of room where chemicals are used or stored. It is the responsibility of the user to be familiar with and adhere to applicable laws and regulations. The user is further advised that Metzger/McGuire will reject any and all responsibility and claims that result from the improper use or storage of our products.

Product Description

Spal-Pro RSF is a fast-setting, two component polyurea polymer intended for filling joints or cracks in industrial concrete floors. Product is composed of a part A (gray liquid) and a part B (amber liquid). When combined at a ratio of 1A:1B (by volume), they react chemically, converting to a solid.

Basic Safety

This product is a chemical and should be handled carefully. Keep away from children, pets, and people not directly involved in its use. Always work in a clean, obstacle-free area that is well ventilated and lit, and where fresh air exchange is constant and adequate. Always use appropriate safety equipment called for in MSDS, including but not limited to splash-guard type chemical eye protection, protective gloves and aprons, a NIOSH/OSHA approved respirator designed for vapor/mist, etc. Avoid contact with skin and eyes. Avoid inhalation and ingestion, especially during reaction. Keep away from flame, pilots, excessive heat.

Chemical Protection Warning

Product is potentially most harmful during chemical reaction, when mild vapor/fumes are released and heat is generated. Inhalation can result in respiratory harm. Reacting product or containers holding same can result in burns.

The "Heavy Duty"
Polyurea Filler for
Class 5-9
Industrial Concrete Floors



INSTALLATION INSTRUCTIONS

IMPORTANT: Thoroughly read MSDS before opening containers or attempting to use

13. Safety Precautions (continued)

Treatment for Exposure

Eye Contact

- Flush eyes with plenty of water for at least 15 minutes and seek medical attention promptly. Take a copy of MSDS, can labels, and this sheet for physician's reference.

Skin Contact

- Rinse thoroughly with soap and water. Follow-up with a skin cleaner cream. If rash or itching develops and persists, visit a physician. Wash affected clothes with laundry detergent and water prior to wearing again.

Sensitivity

- Some people are very sensitive to polyurea polymers. Sensitivity may be indicated by continued dermatitis (rash, itching, burning), shortness of breath, etc. If sensitivity symptoms occur, the person should be promptly removed from all further exposure. Sensitivity can be cumulative.

Inhalation

- Avoid inhaling polyurea components individually and especially when reacting in combination. If vapors or fumes are inhaled, seek fresh air immediately. If breathing is labored, give oxygen and seek medical help immediately. If breathing has stopped, administer artificial respiration until medical help arrives.

Ingestion

- Do not ingest. If ingested, do not induce vomiting. Seek medical help immediately if either part or both parts are ingested. Provide physician with Material Safety Data Sheet (MSDS) and labels.

Special Precaution - Sanding of Cured Product

Sanding of cured product (and adjacent concrete) can release harmful fumes and airborne dust, etc. All personnel in affected area should wear appropriate respirator or be removed from area.

Containers

Dispose of all empty containers, and other disposable items in full compliance with all applicable local, state and federal laws. Do not incinerate sealed containers.

13. Warranty

Metzger/McGuire Co. solely and expressly warrants that its product shall be free from defects in material and workmanship for 12 months from the date of purchase (180 days for dual cartridge units). Unless authorized in writing by an officer of Metzger/McGuire, no other representations or statements made by Metzger/McGuire or its representatives, in writing or orally, shall alter this warranty. Metzger/McGuire makes no warranties, implied or otherwise, as to the merchantability or fitness for ordinary or particular purposes of its products and excludes the same. If any Metzger/McGuire product fails to conform with this warrant, Metzger/McGuire will replace the product at no cost to the purchaser. Purchaser's sole remedy in any case shall be limited to the purchase price or replacement cost of product and specifically excludes labor and the cost of labor, lost wages and opportunity costs, and all other possible incidental, consequential or special damages resulting from any claim of breach of warranty, breach of contract, negligence or any legal theory. Any warranty claim must be made within one (1) year from the date of material purchase. Metzger/McGuire does not authorize anyone on its behalf to make any written or oral statements which in any way alter the installation procedures or written installation instructions published in its product literature or on its packaging labels. Any installation of Metzger/McGuire products which fails to conform with such installation information or instructions shall void this warranty. Purchaser shall be solely responsible for determining the suitability of Metzger/McGuire's products for the purchaser's intended purpose.

02/08



Customer Service - (800) 223-MM80 - Technical Assistance

E-Mail: specmm80@aol.com • Web Site: www.metzgermcguire.com